

G. H. FOX.

Breech Loading Fire Arm.

No. 98,579.

Patented Jan'y 4, 1870.

Fig. 1.

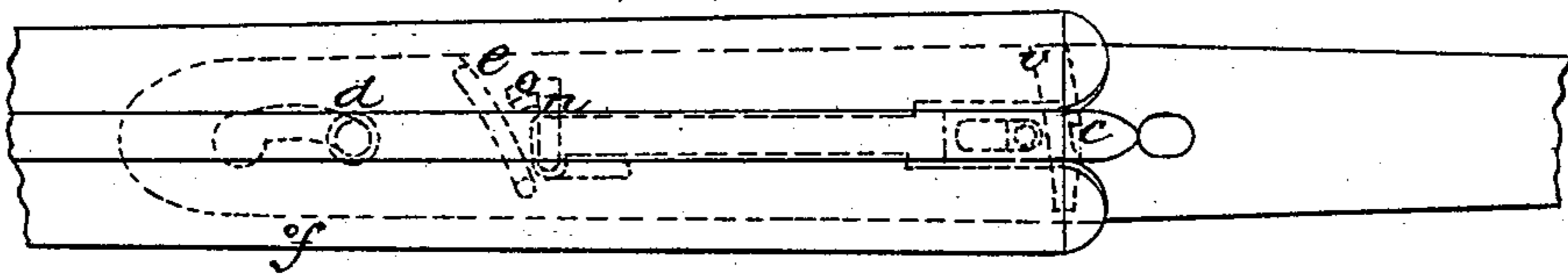

Fig. 4.

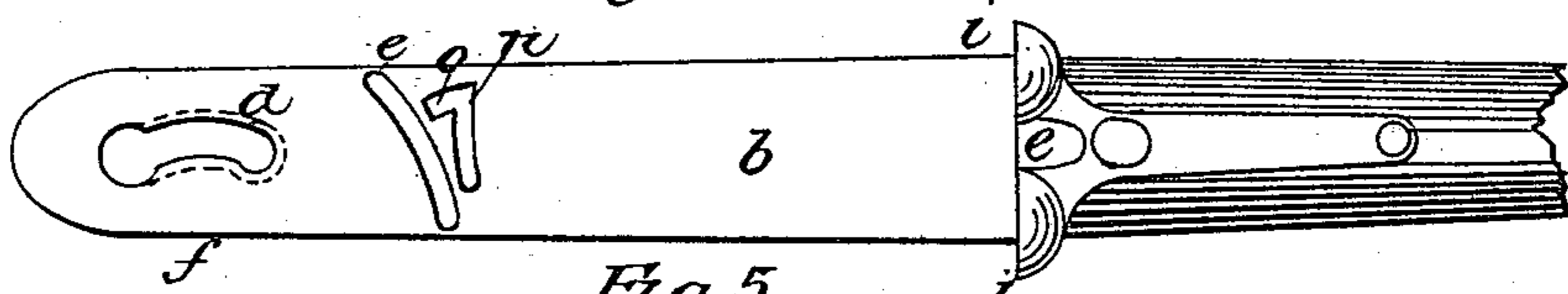

Fig. 5.

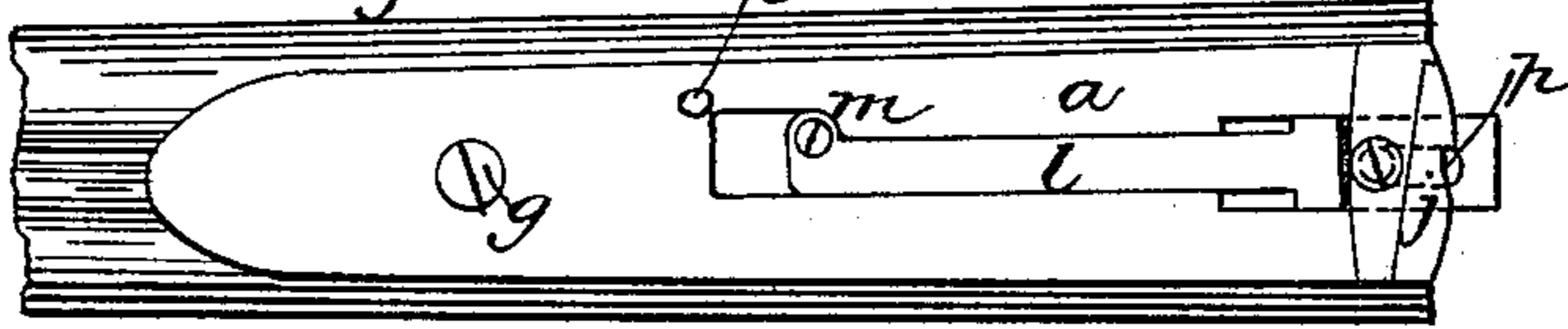

Fig. 3.

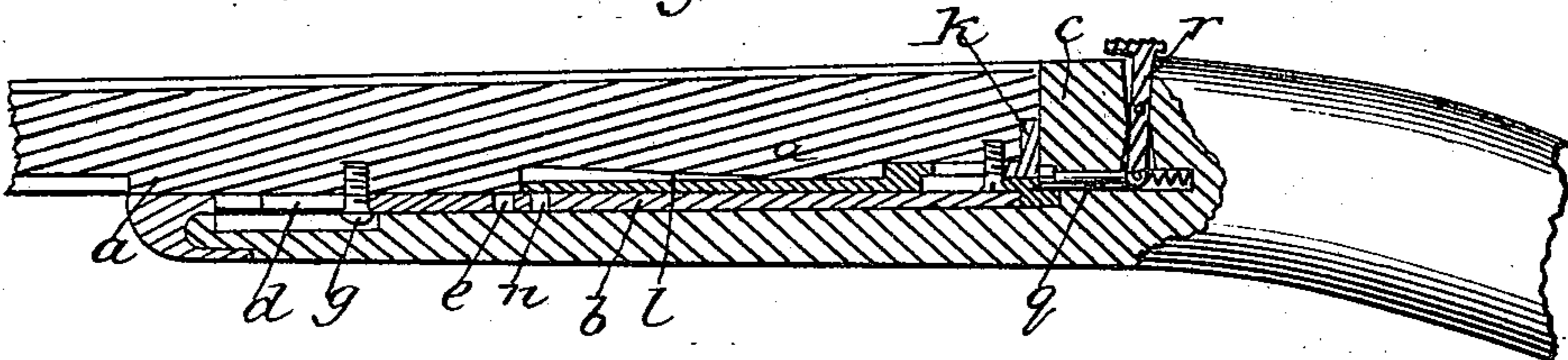
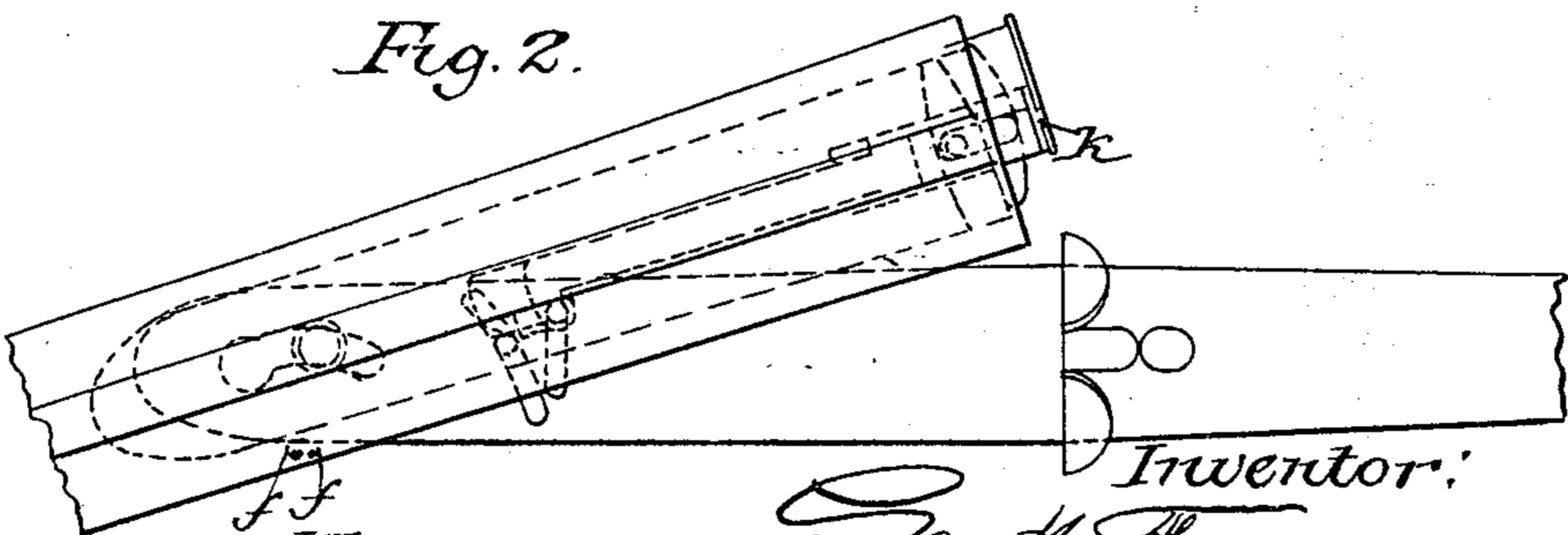

Fig. 2.



Witnesses:
G. B. Redder
A. W. Frothingham

Inventor:
Geo. H. Fox,
by his Atty
Crosby, Halsted & Bond.

United States Patent Office.

GEORGE H. FOX, OF BOSTON, MASSACHUSETTS.

Letters Patent No. 98,579, dated January 4, 1870.

IMPROVEMENT IN BREECH-LOADING FIRE-ARMS

The Schedule referred to in these Letters Patent and making part of the same.

To all whom it may concern:

Be it known that I, GEORGE H. FOX, of Boston, in the county of Suffolk, and State of Massachusetts, have invented Improvements in Breech-Loading Fire-Arms; and I do hereby declare that the following, taken in connection with the drawings, which accompany and form part of this specification, is a description of my invention, sufficient to enable those skilled in the art to practise it.

This invention relates to improvements by which the barrels of double-barrelled guns are vibrated to one side or the other, (preferably to the right at the rear,) for the purpose of opening the barrels at the breech, to insert or extract fixed ammunition, or to extract the empty shells, the barrels being brought back and locked securely in line for firing, by movement in a reversed direction.

If the barrels were hung on a fixed pivot in the plane of the right line, connecting them to the stock, the rear or breech-end and the breech-block would have to be made as arcs of circles, which would not fit the plane surfaces of the ends of cartridge-shells, now in common use, and if they were connected to a pivot or pivots, on which the barrels turned, such pivot or pivots, to cause the rear of the barrels to move forward sufficiently to clear the breech attached to the stock, would have to be located outside of the smooth symmetrical outline of the gun, and would make inconvenient and unsightly protuberances beneath the barrels.

Now, my invention consists in a gun, so constructed that the barrels can be moved to open and close the breech, by a sidewise vibration from a point of vibration or oscillation outside of the outline of the stock; but instead of being guided by an actual pivot, fixed at said point, the barrels are guided and controlled, in the side vibrations or oscillations given them, by pins working in grooves, made concentric with a centre outside of the outline of the gun, which centre is shown on the drawings, and may be termed an imaginary centre, because of the absence of an actual pin or pivot at the centre point; and

My invention further consists in details, herein set forth, connected with the operation of the extractor.

Figure 1, of the drawings, shows, in plan, those parts of a gun embodying my invention, the position being that in which the parts are in readiness for explosion of the charges.

Figure 2 is a plan of the same, with the parts in position for the insertion of full, or the withdrawal of full or empty shells. In said view, a shell is shown only in the right-hand barrel.

Figure 3 is a vertical longitudinal section, taken in the central plane between the barrels, and showing the parts in position for explosion of the charges.

Figure 4 is a plan of the stock, with the barrels removed.

Figure 5 is a plan of the under side of the rear end of the barrels.

The barrels have fixed to their under side, at the rear, a flat plate, *a*, and the frame to which the stock is attached is made with a plate, *b*, integral with the breech *c*, extending under the rear of the barrels.

In the plate *b* are cut grooves *d* and *e*, concentric with a centre at *f*, which is located, as seen in figs. 1, 2, and 4, outside of the outline of the stock.

In the barrel-plate *a* are fixed two pins, *g* and *h*, the pin *g* being preferably made to screw into the plate *a*, and having a head, which fits under the plate *b*, the slot *d* being enlarged at the end most remote from the breech, to pass the pin *g* into and out of the groove *d*.

The pin *h* enters and traverses the groove *e*, and, by abutting against the right-hand end of said groove, limits the movement of the barrels to the right.

Adjacent to the breech *c*, a depression is made, having one boundary *i*, concentric with the centre *f*, and a projection, *j*, is fixed to the plate *a*, at its rear, having one boundary or edge coincident with the boundary *i* of the depression just referred to.

The head of *g* keeps the plates *a* and *b* in close contact, and to keep the overhanging end of the barrels from tipping downward, when the barrels are brought into line for firing, the piece *j* may be extended as a lip, as shown, to the rear of the barrels, to engage in a groove made in the face of the lower part of the breech, or the piece *j* may be bevelled, on its circular edge, to fit a similar suitable bevelling, which may be given the outline *i*.

The cartridge-extractor is a simple slide, with its rear end formed to surround a portion of the shells, when placed in the barrels, said end, when the barrels are in position for firing, being embedded in a suitable recess formed in the rear end of the barrels. This end is denoted by *k*, and the shank or slide, which is fitted in a groove made in the plate *a*, is marked *l*, and is made as a spring, the yielding end of which is enlarged, as seen in fig. 5, to prevent its accidental withdrawal, and is provided with a pin, *m*, which moves in, and is with the extractor, moved by traversing the slot *n*, formed, as shown in fig. 4, as cut in plate *b*.

When, in swinging the barrels to the right, pin *m* strikes against the extreme right-hand boundary of the slot *n*, said pin forms a check to further right-hand movement of the barrels, and in that position, shown in fig. 2, the rear of the barrels clears the breech sufficiently for extraction or insertion of cartridges.

In moving the barrels to said position, the action

of pin *h* in slot *e* has served to draw the barrels forward away from the breech, and the pin *g* will be in the slot *d*, in the position shown in fig. 2.

In closing the rear of the barrels, the projection *j*, acting against the outline *i*, acts with the pin *h* and slot *e* in drawing the rear of the barrels firmly to the breech.

When the parts are in the position shown in fig. 2, the cartridge-extractor can be pushed home, with its rear flush with the rear of the barrels, the pin *m* then moving in the part *o* of the groove *n*, and as the barrels are brought back into line, the pin *m*, which is inclined or bevelled on its end, rides up on the bevelled or inclined inner side of the slot *o*, and passing over the surface of the plate *b*, springs back into the slot *n*, near the left-hand end thereof, in readiness to push the extractor and cartridges rearward, when the barrels are next swung outward.

When it is desirable to detach the barrels from the stock, the fingers of the right hand conveniently elevate the spring-end of the extractor, when the barrels are in position seen in fig. 2, and then the barrels can be swung further to the right, till pin *h* touches the right-hand end of slot *e*, which will have the effect to move forward the barrels, and will bring the head of pin *g* to the enlarged end of slot *d*, from which the pin can then be lifted, and the barrels will then be free from the stock.

To replace the barrels, drop the pin *g* in the enlarged part of the slot *d*, and pin *h* in slot *e*, and move

the rear of the barrels to the left, raising the spring-end of the extractor, so that pin *m* will pass over the plate *b* into the slot *n o*.

To lock the barrels in position for firing, any suitable means may be employed, those seen in fig. 3 answering as well as any.

In the projection *j*, or in the rear of the barrels, a notch, *p*, is cut, in which a spring-latch bolt, *q*, catches and holds, until retracted by the action of the thumb on the exposed roughened end of lever *r*.

A gun made and operating as described is simple, cheap, effective, and not apt to get out of order.

I claim—

1. A gun, in which the barrels are made movable on the stock to the right or left, and forward and back, for the purpose of opening and closing the breech, for loading, unloading, or extracting empty shells, when the movement is controlled by the action of pins or projections within or on curved boundaries struck from an imaginary centre, and without employment of a pivot at such centre.

2. The means for operating the extractor, consisting substantially of a yielding or spring sliding shank, provided with a pin, gearing in the slot *n o*, the pin or the slot, or both, being bevelled for the purpose described.

GEO. H. FOX.

Witnesses:

FRANCIS GOULD,
S. B. KIDDER.